



9000XE rinse mixer

Designed to meet the demanding requirements of professional kitchens, this mixer combines a sleek, durable design with materials that are easy to clean and keep hygienic. It is completely lead-free and equipped with easy-grip handles as well as a built-in diverter function that makes it simple to switch between the spout and the flexible spray nozzle.

The mixer responds quickly to changes in pressure and temperature, ensuring a consistent and safe water temperature. The automatic hot-water lock also provides complete scald protection. Delivered with a 10-year 9000XE functional guarantee for extra peace of mind in everyday use.

Article number: 86655000 **RSK:** 8410019 **Flow 3 bar:** 16.0 l/m

Description: Chrome, 160 c/c

Unique characteristics



Backflow protection unit type 

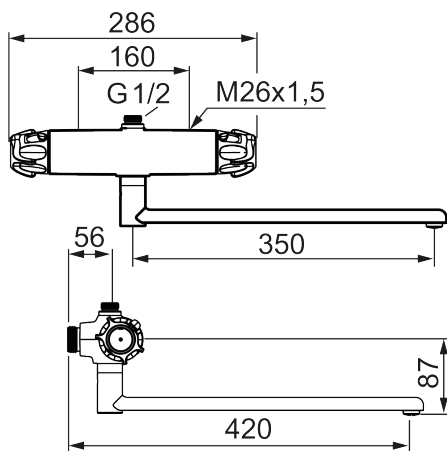

- Pressure balanced thermostatic mixer
- Temperature handle with safety stop 38°C
- With Eco-function
- Lead Free material
- With approved non-return valves, EN-Standard EN1717
- With swivel spout, length 350 mm
- With care-handle